

8010N

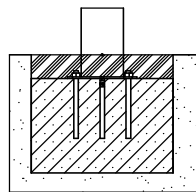

8010F

8010

8010N

E1

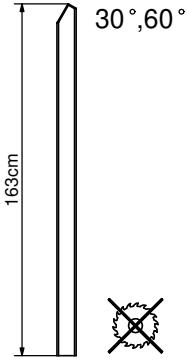

x4

E2

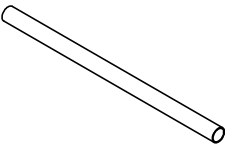

L=59 cm

x4

E3

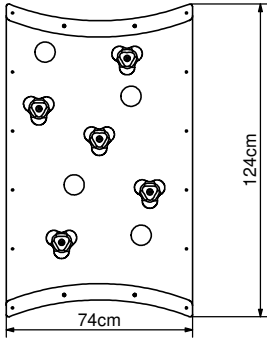

x1

E4

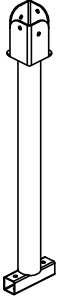

x4

E5

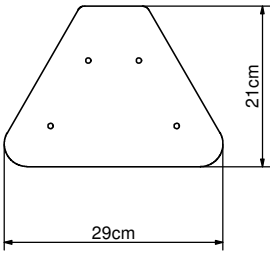

x4

E6

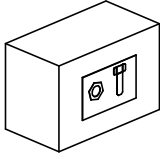

x1

8010F

E1

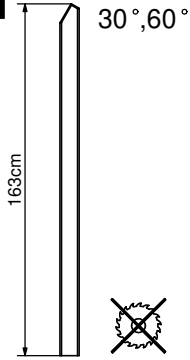

x4

E2

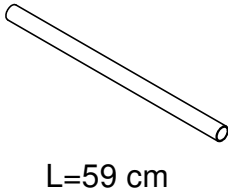

x4

E3

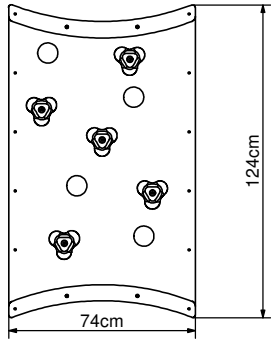

x1

E4

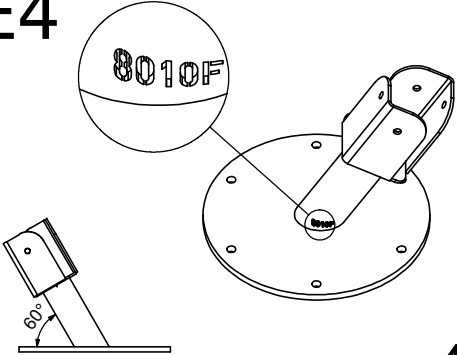

x4

E5

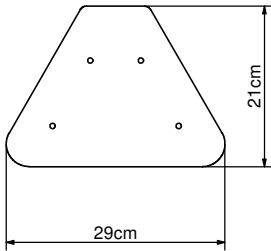

x4

E6

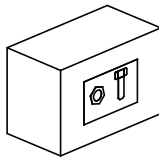



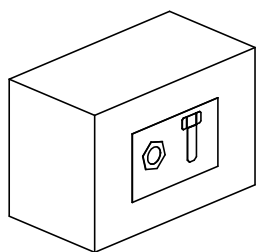







x1

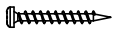

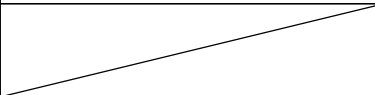
8010N

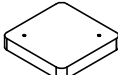
8010F

Nr	Element			Σ	Σ
1		-	S6x60	61	61
2		-	W6x60	44	44
3		-	K2_d30_B	1	1
21		DIN 125	8x16	17	17
26		-	S4x40	4	4
58		-	LOCTITE	1	1
61		-	KL105		24
109		DIN 913	10x10		16
149		-	ALUZ SD	8	8
181		-	F80X_6_PE_g15	2	2
213		-	Z_NA_1	1	1
214		-	Z_NA_2	1	1

8010N
8010F

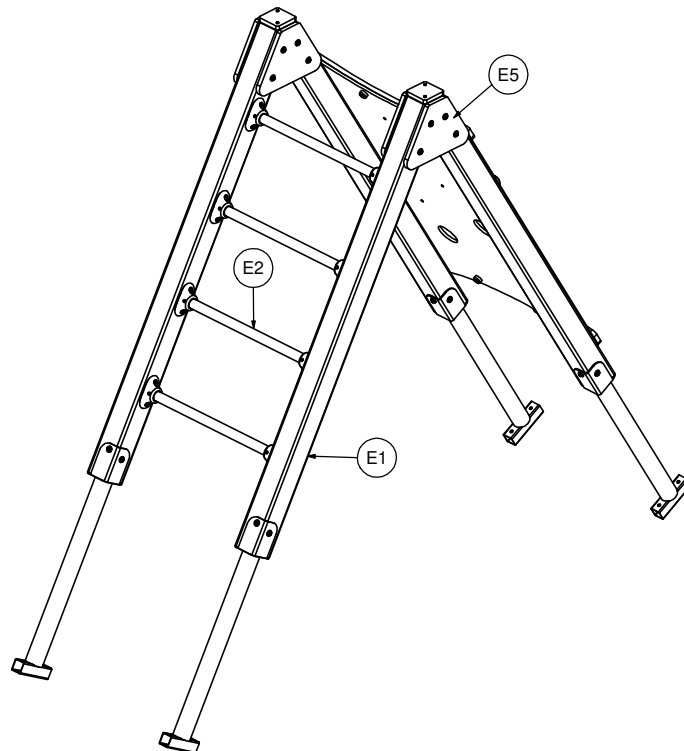
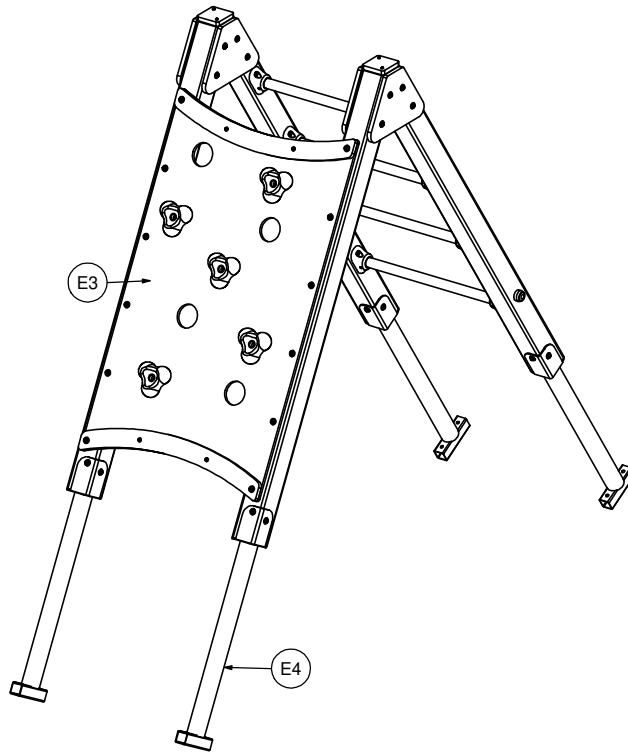

1

8010N
8010F

INST_80_6



2

8010N
8010F

INST_80_43

INST_80_44B

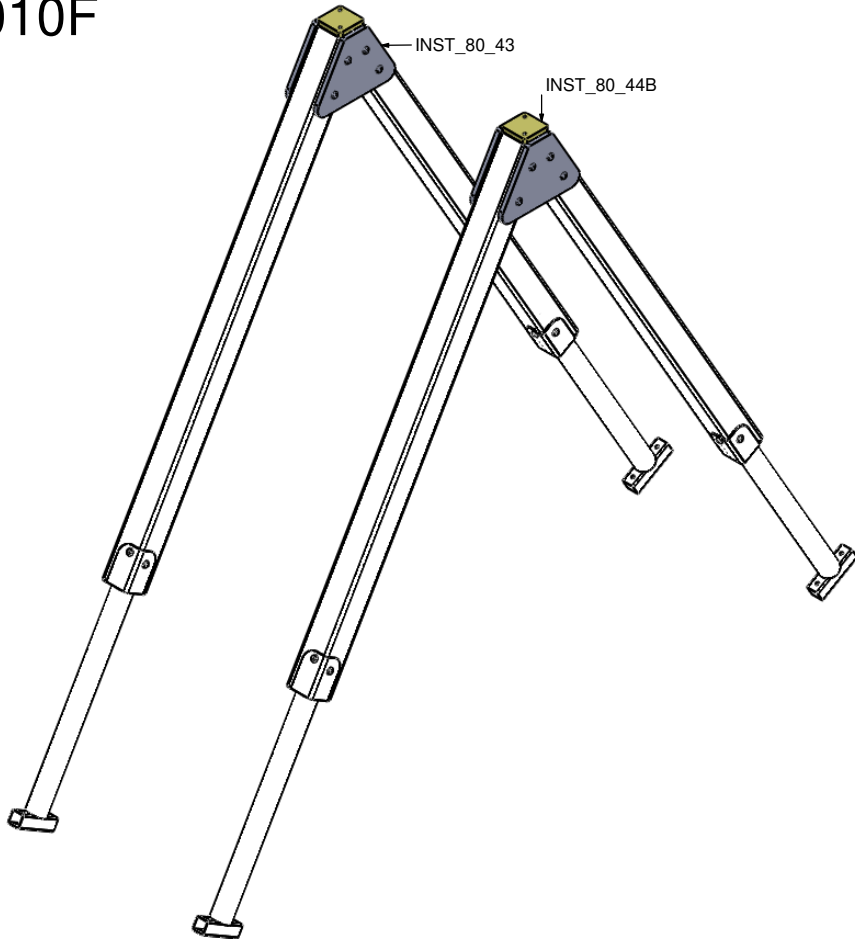

3

8010N
8010F

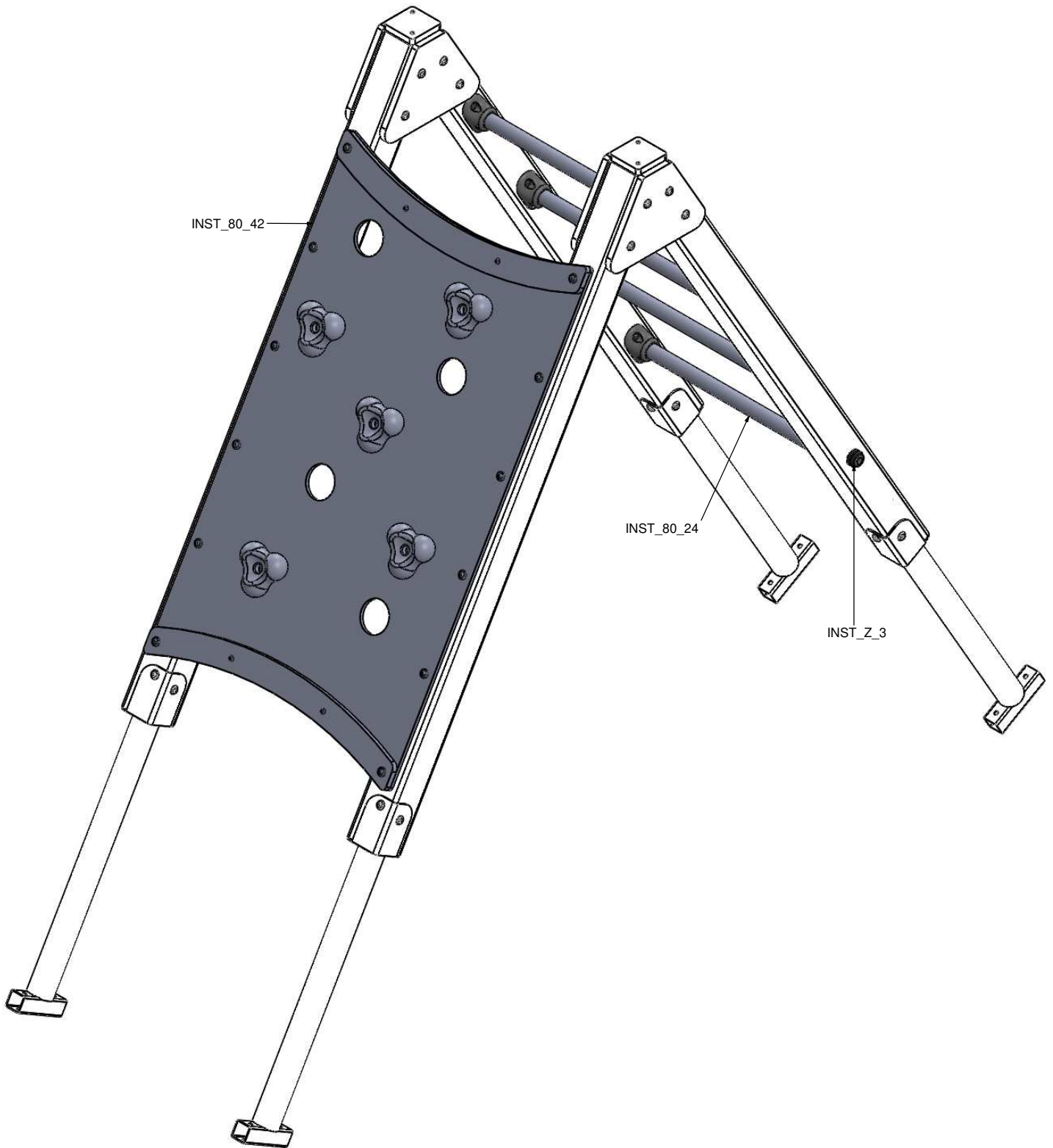

8010N
8010F

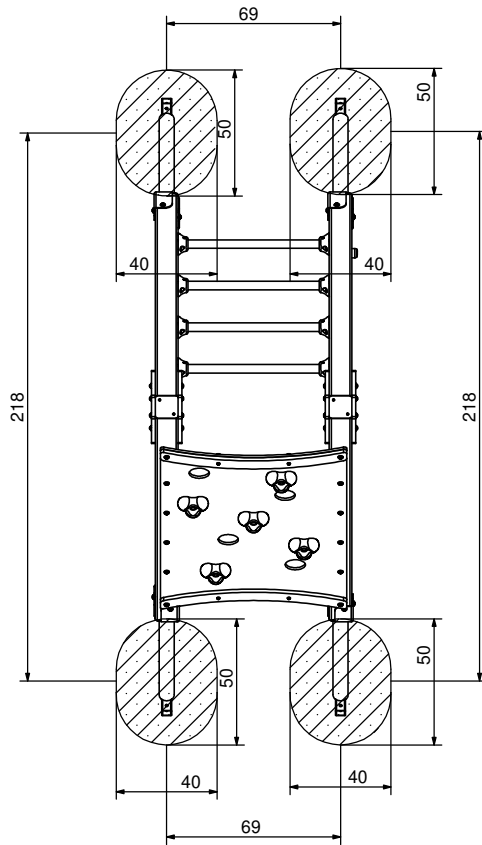
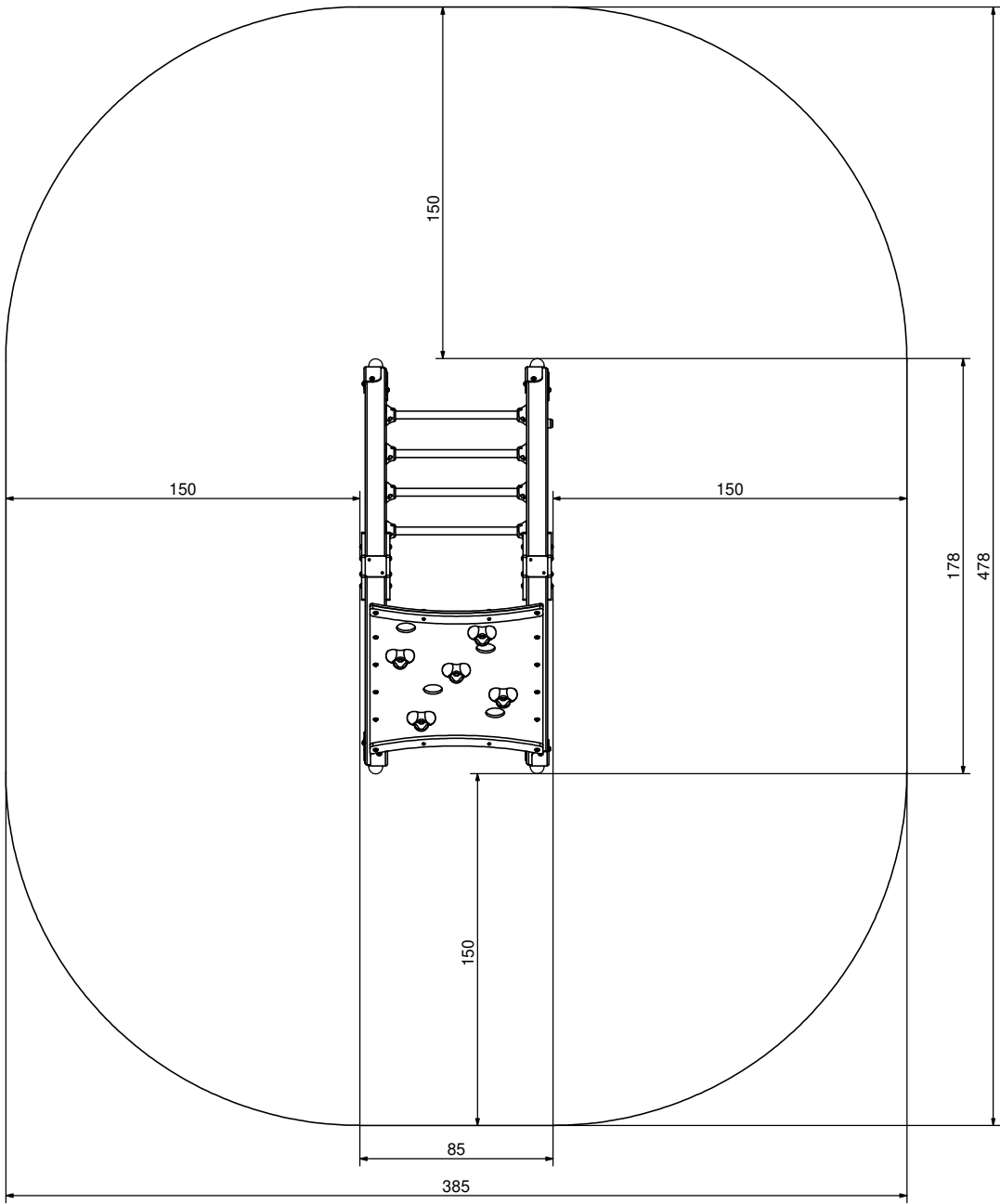

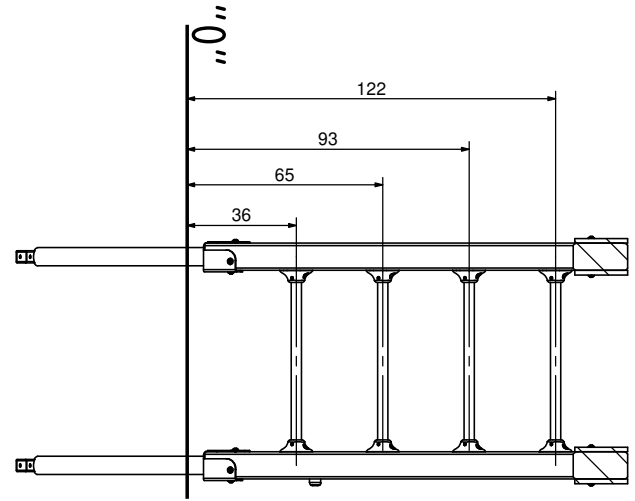
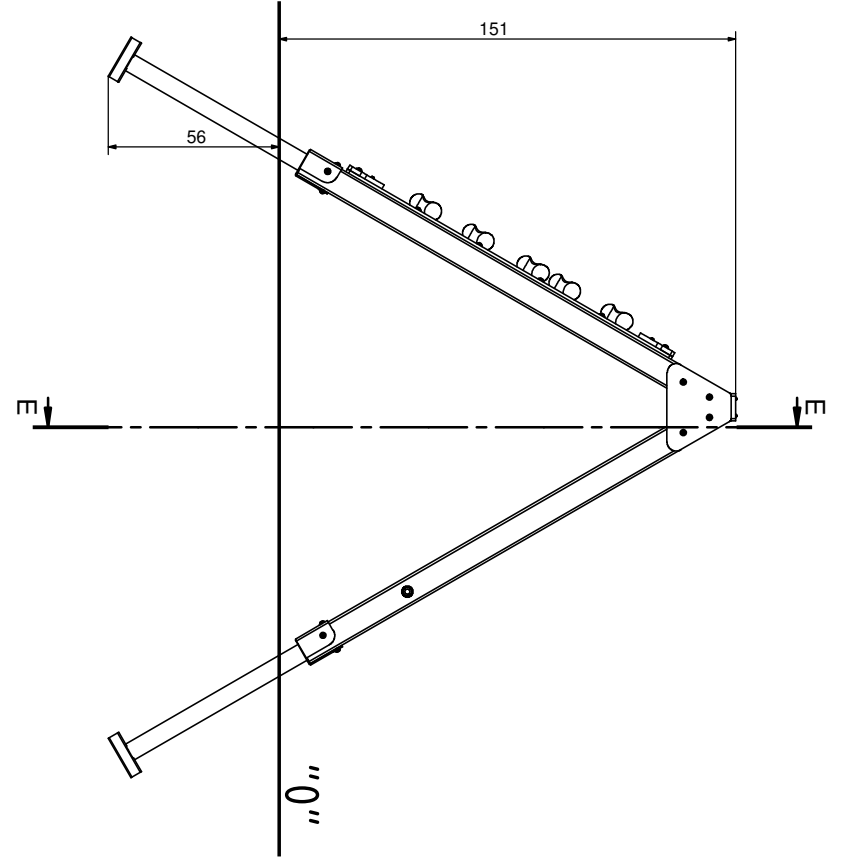
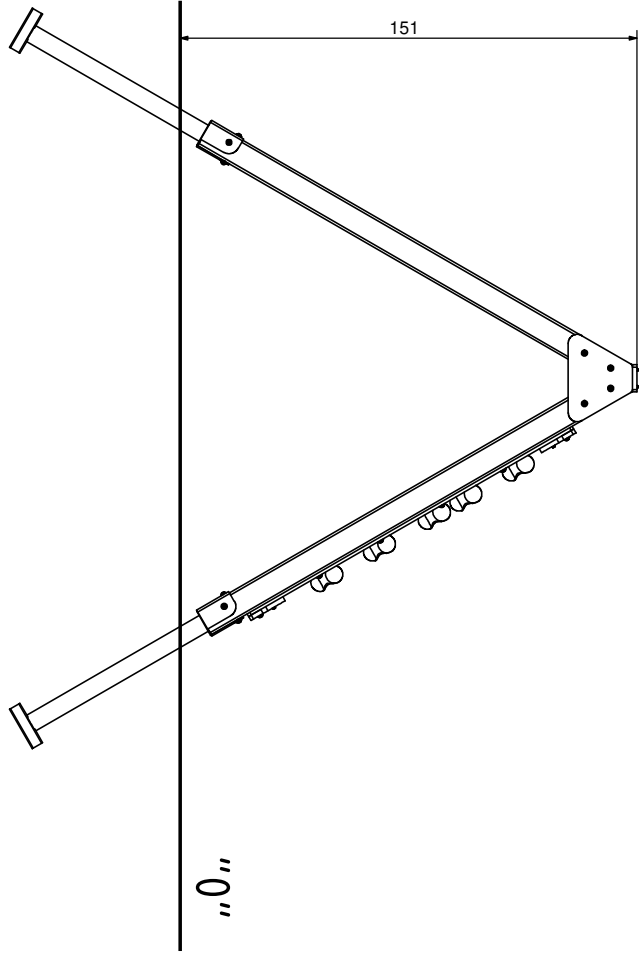

8010N

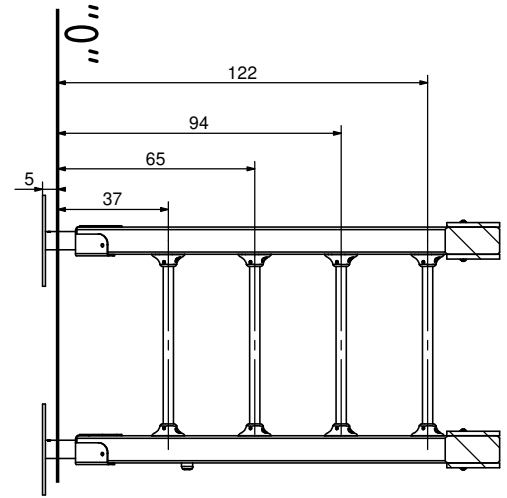
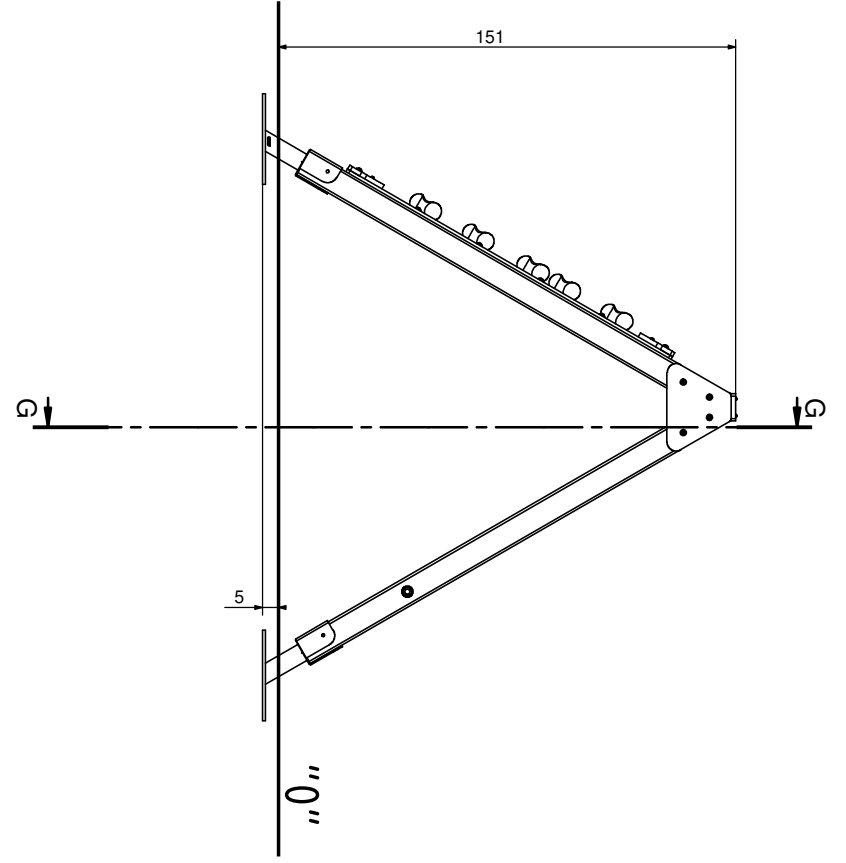
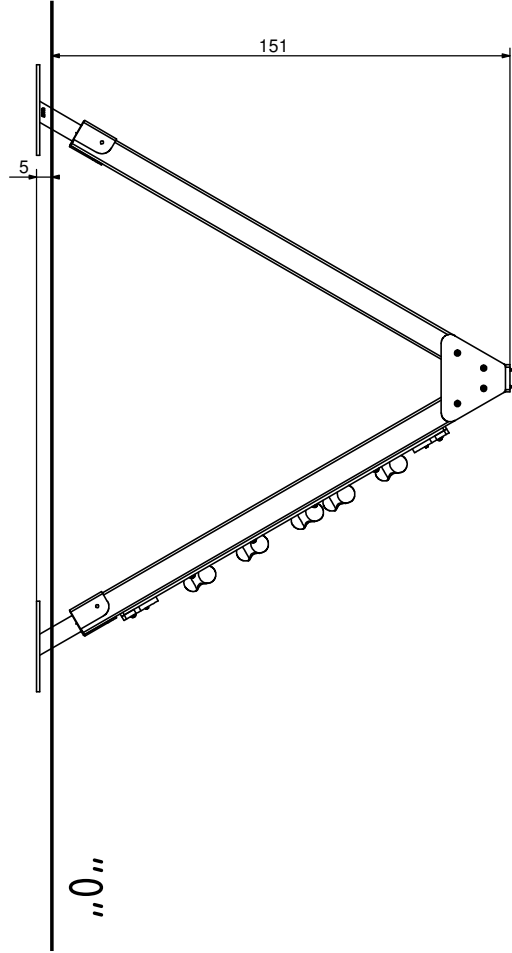

8010N

B15 0,2m³ min. 24H

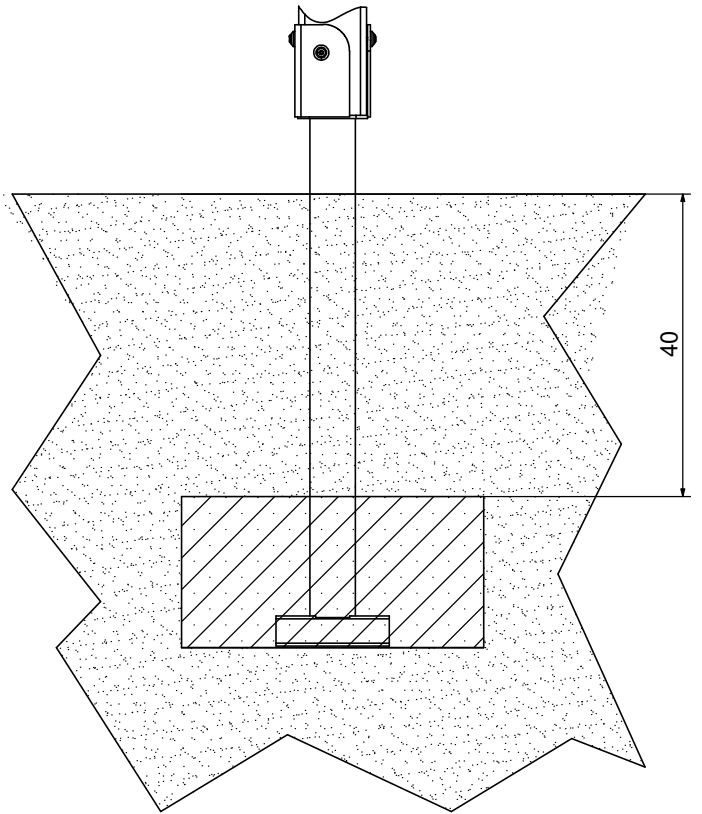
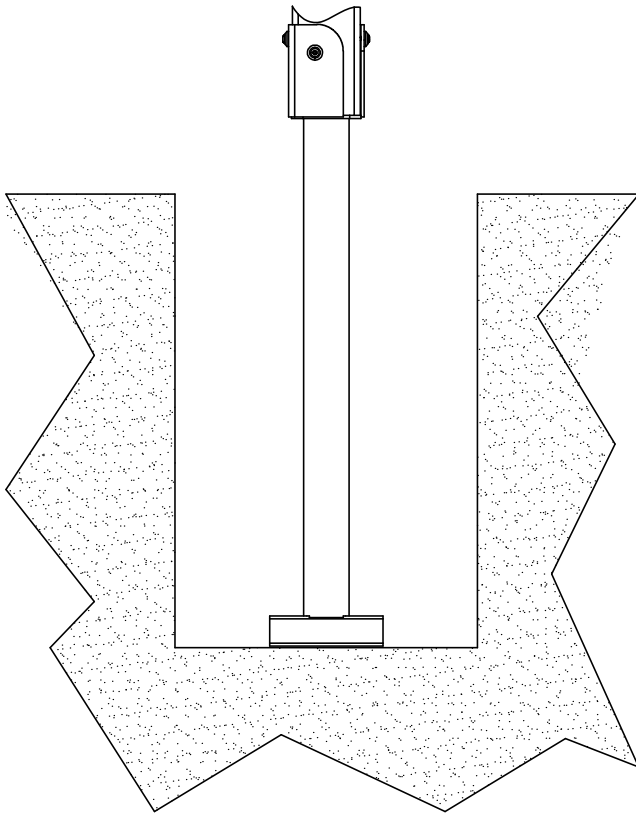
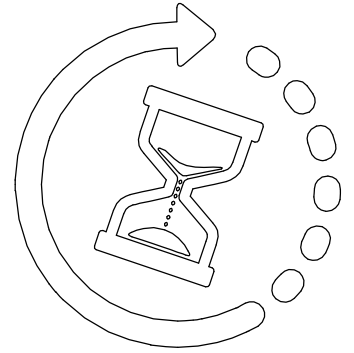
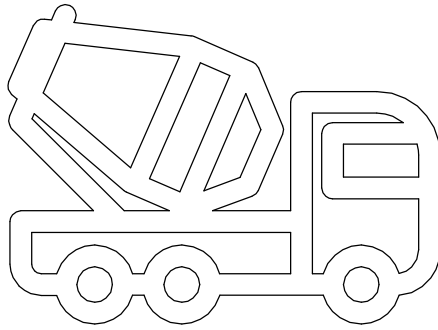
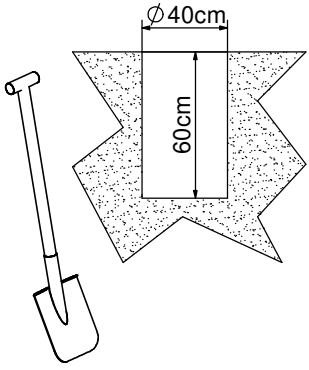

8010F

I

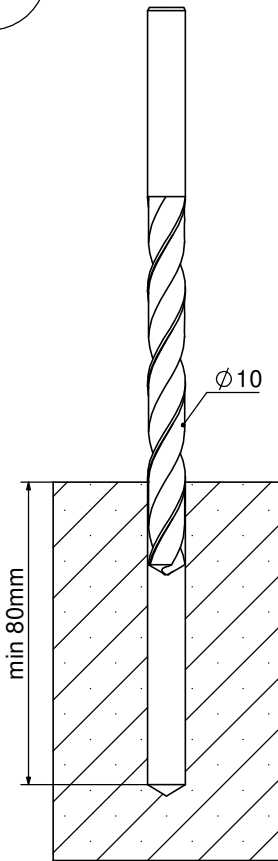

II

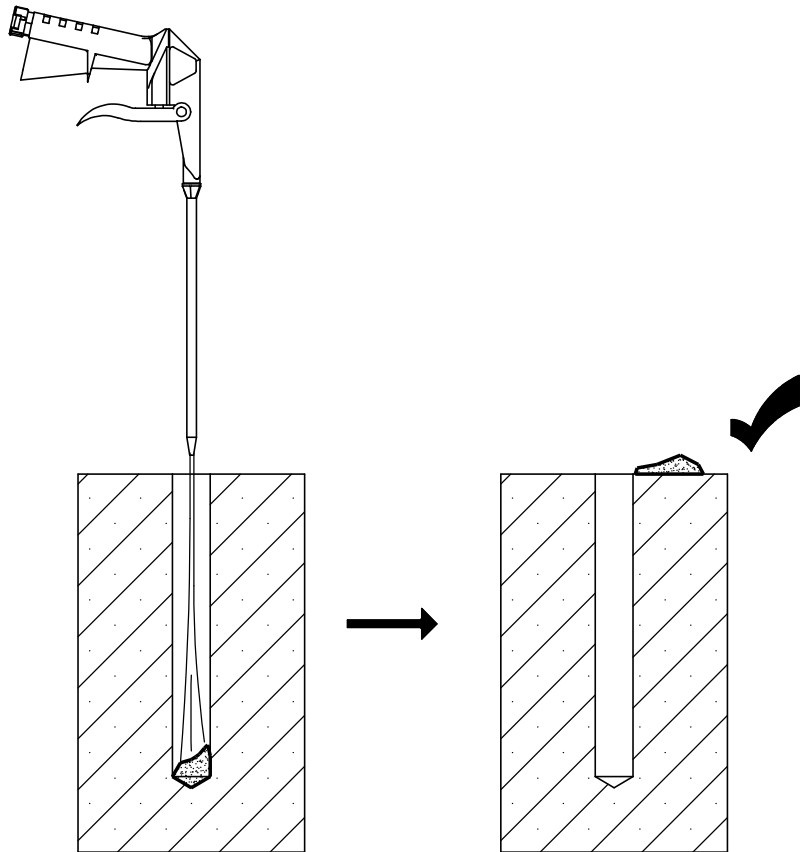

III

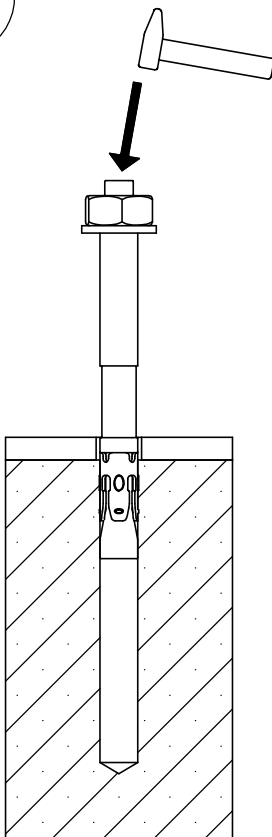

IV

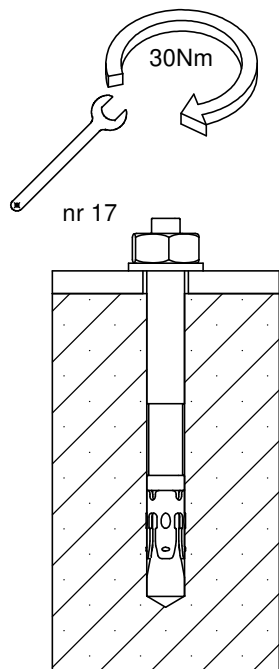

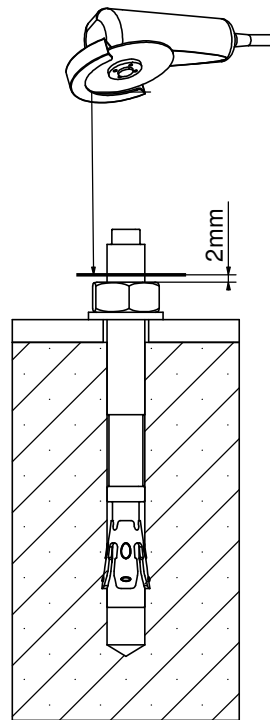

V

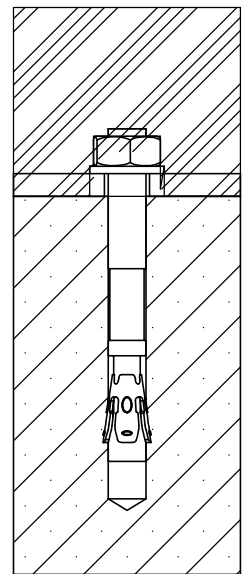

VI

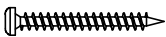

INST_80_6

Nr:	Σ	Element:	
1	4x	S6x60	
2	4x	W6x60	

N

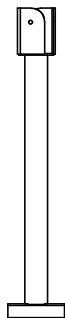



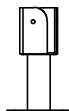

F

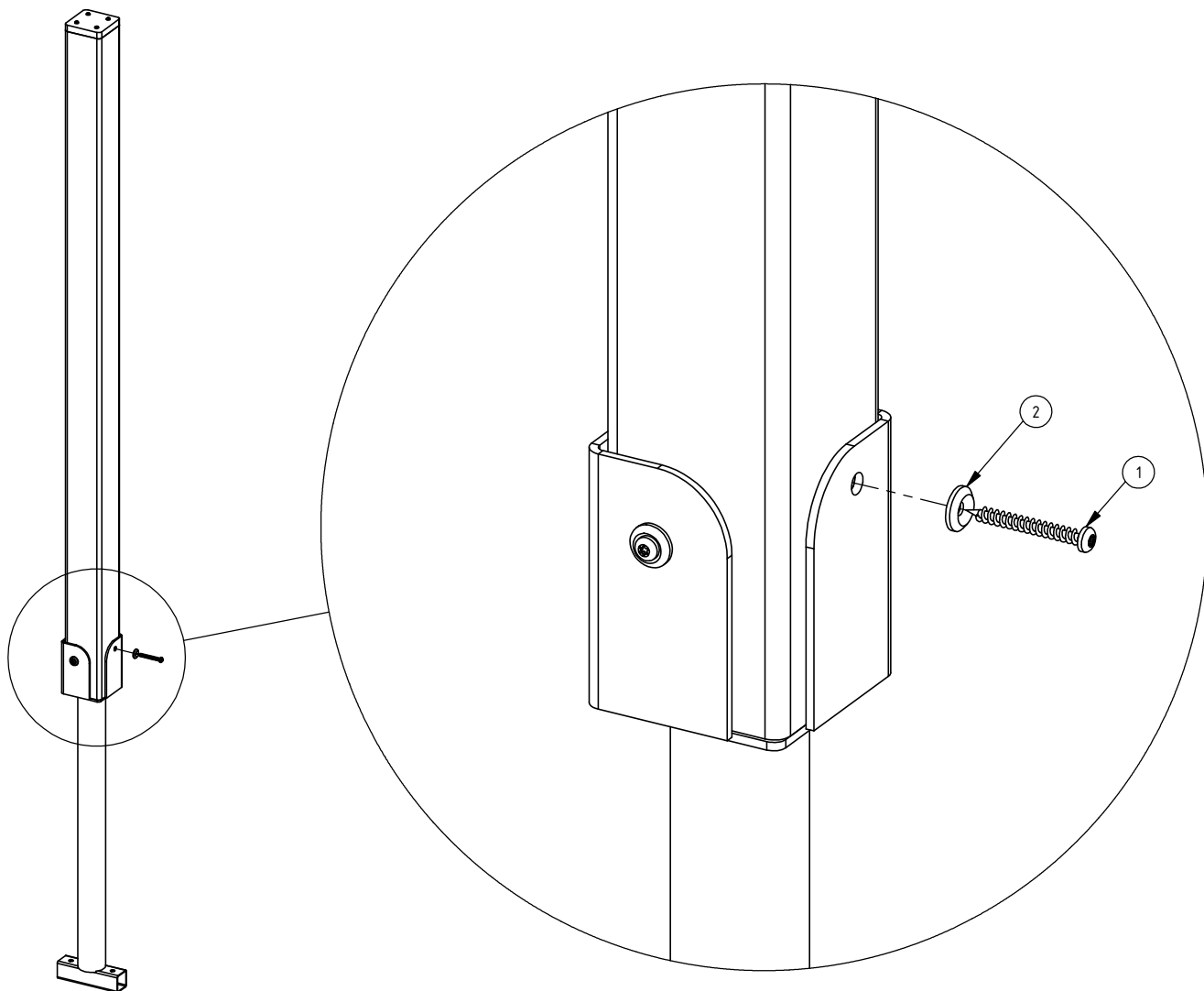

A (1 : 3)

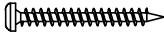

INST_80_24

Nr:	Σ	Element:	
1	4x	56x60	
21	4x	DIN 125 - 8x16	
109	4x	DIN 913 10x10	
149	2x	ALUZ SD	

1

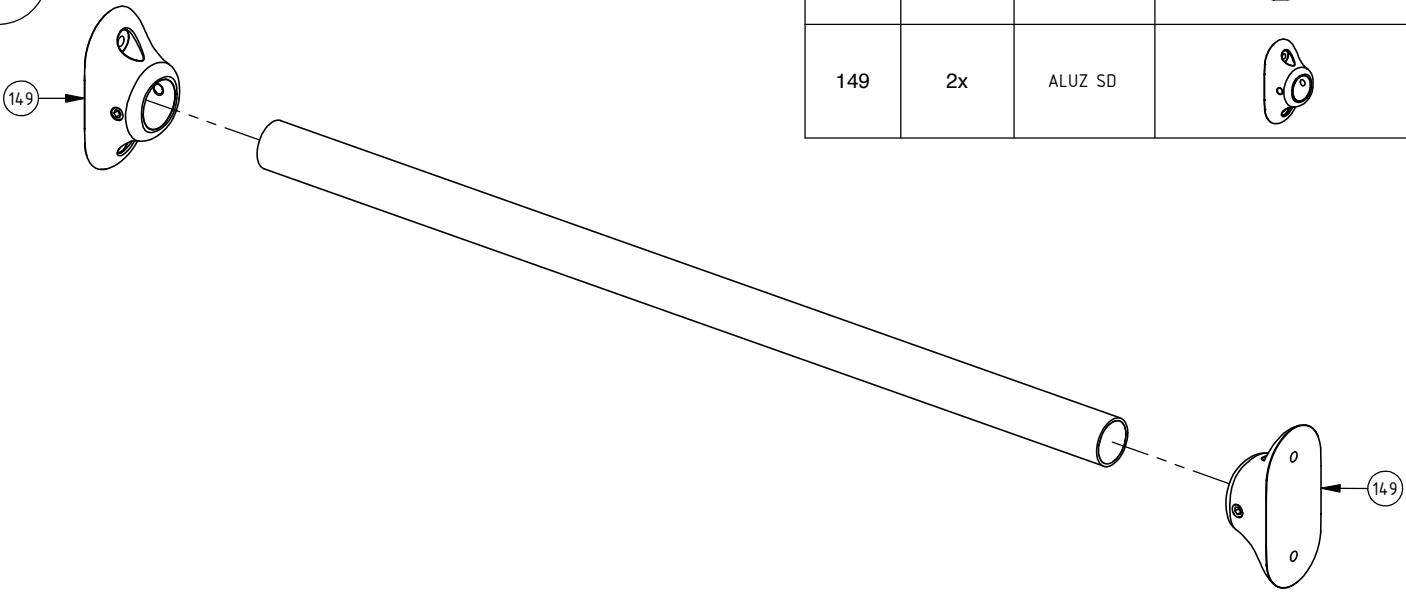

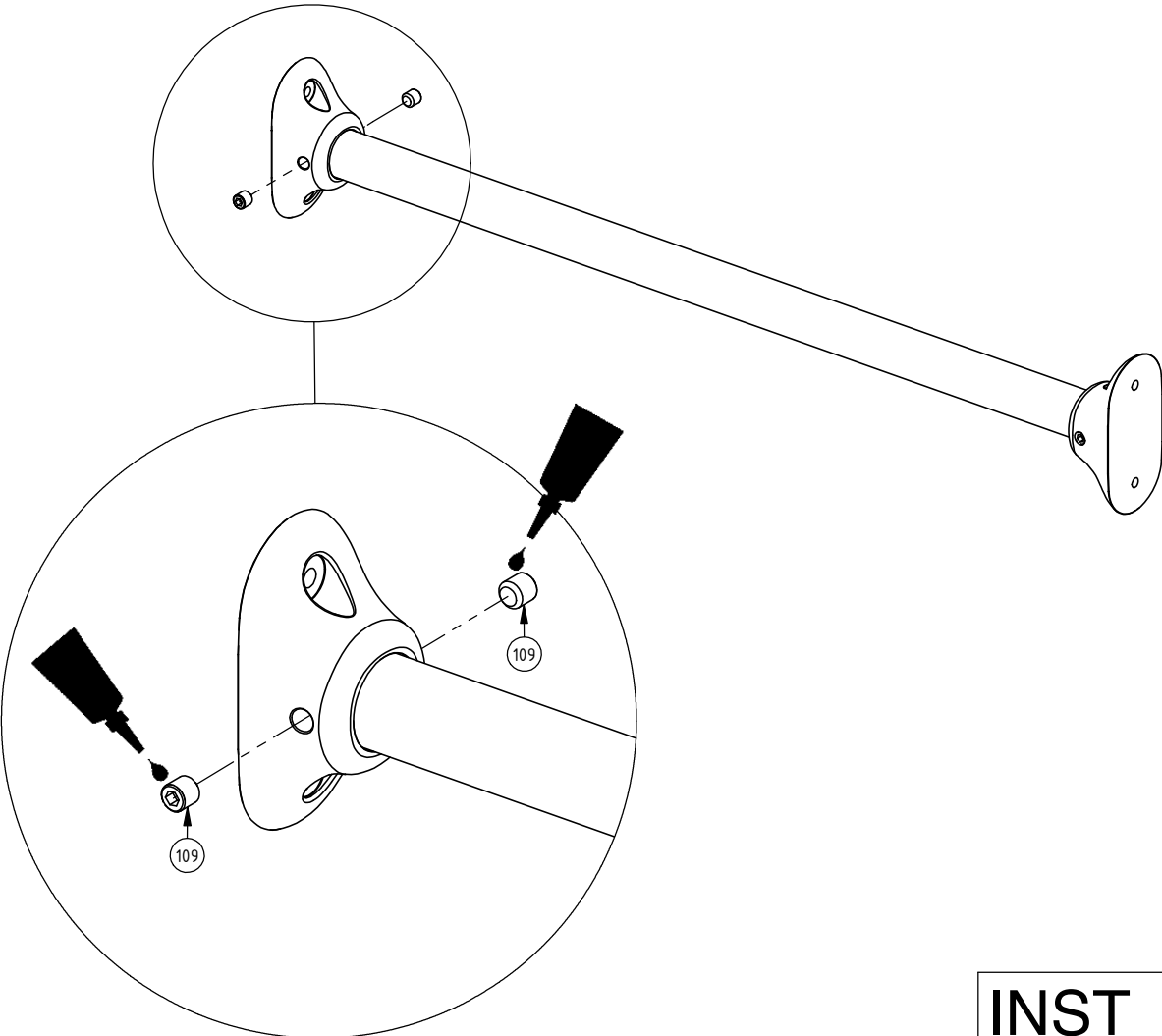

2

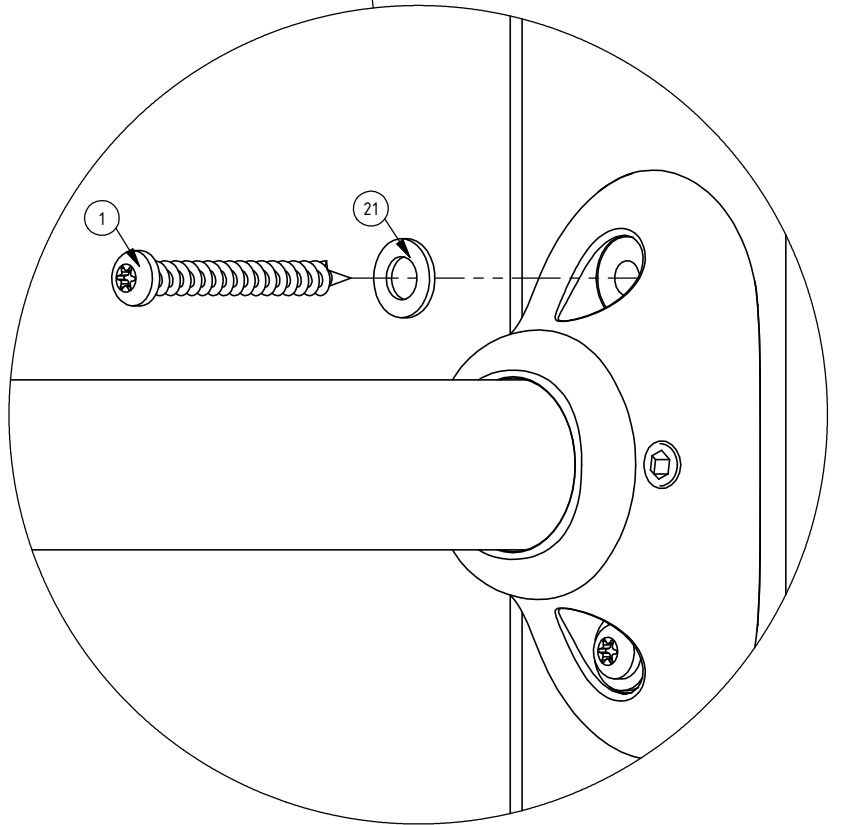
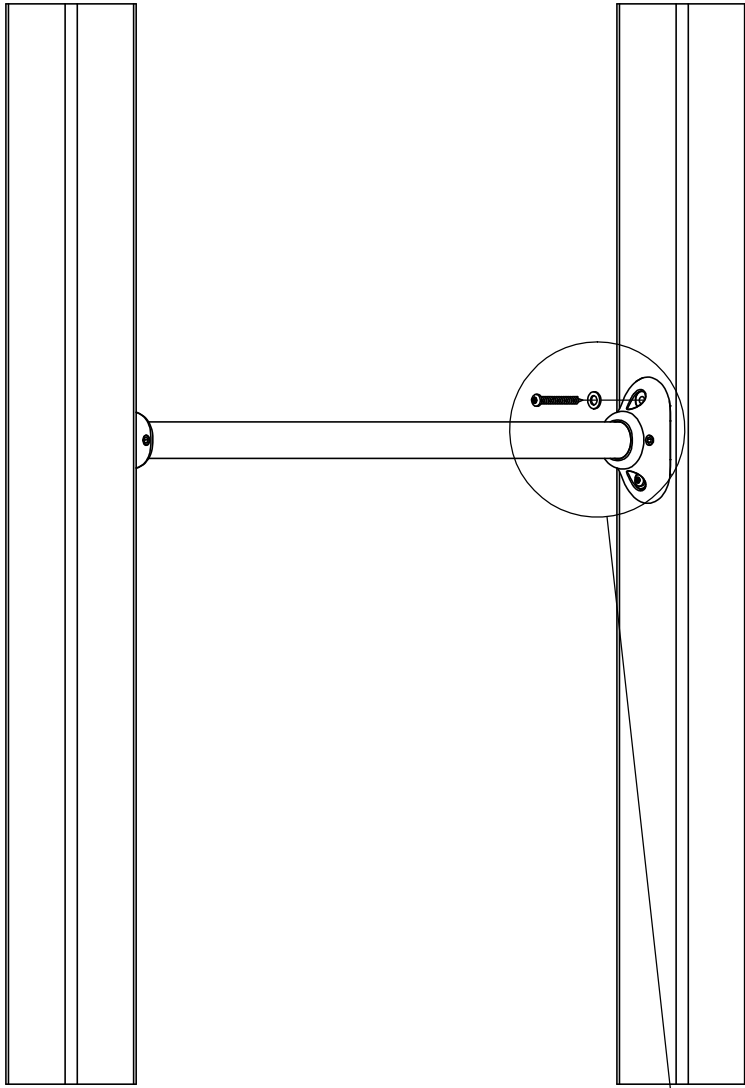

3

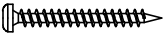

INST_80_42

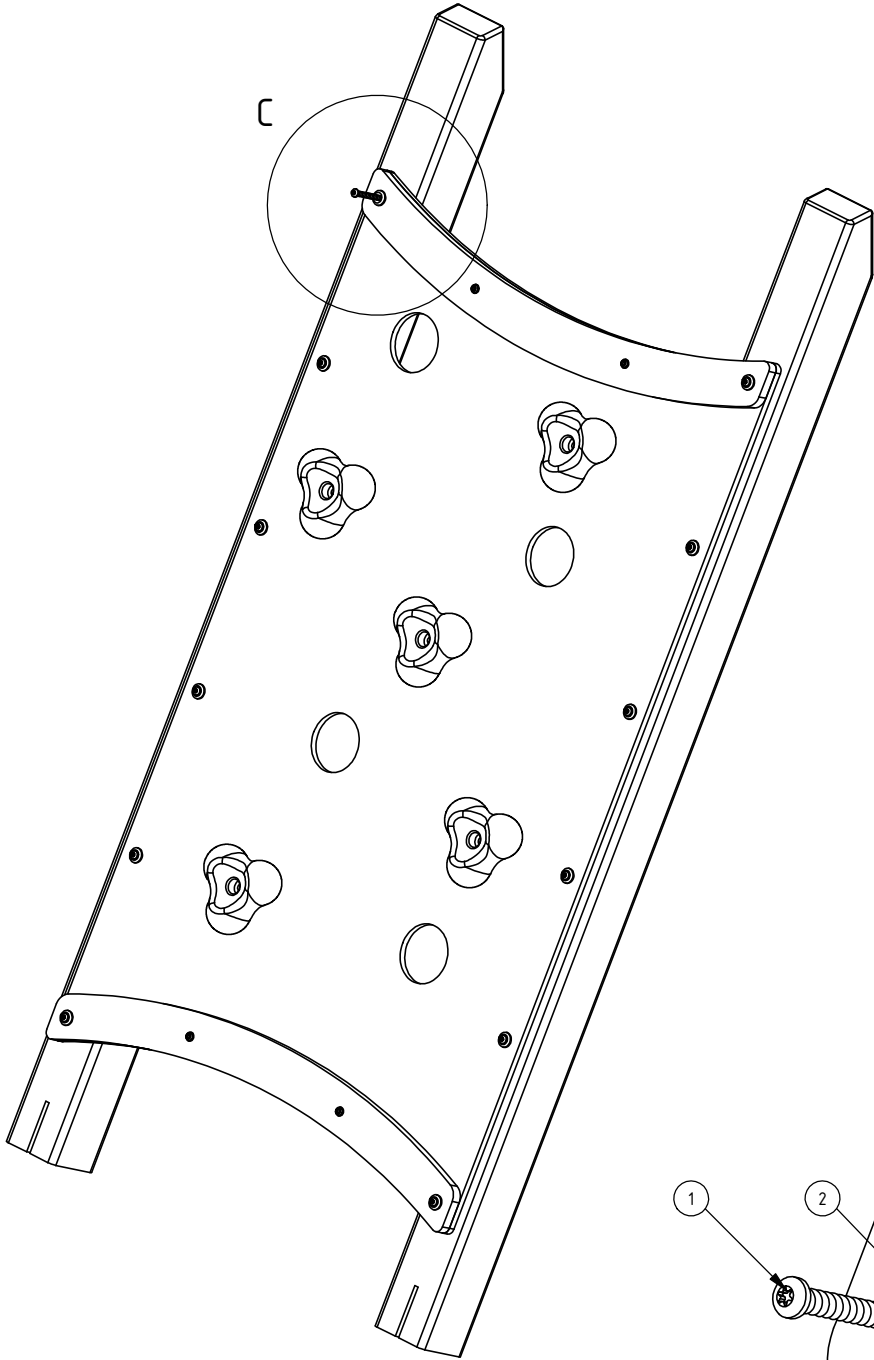

Nr:	Σ	Element:	
1	12x	S6x60	
2	12x	W6x60	

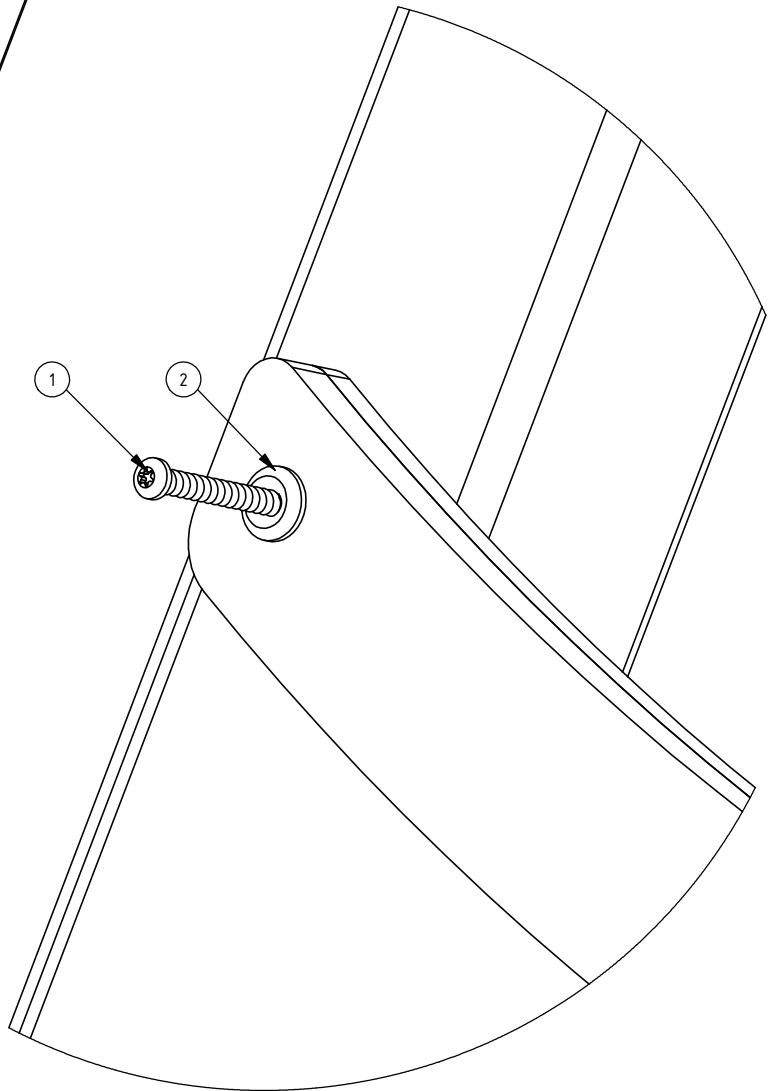

C (1 : 2)

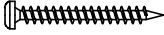

INST_80_43

Nr:	Σ	Element:	
1	4x	S6x60	
2	4x	W6x60	

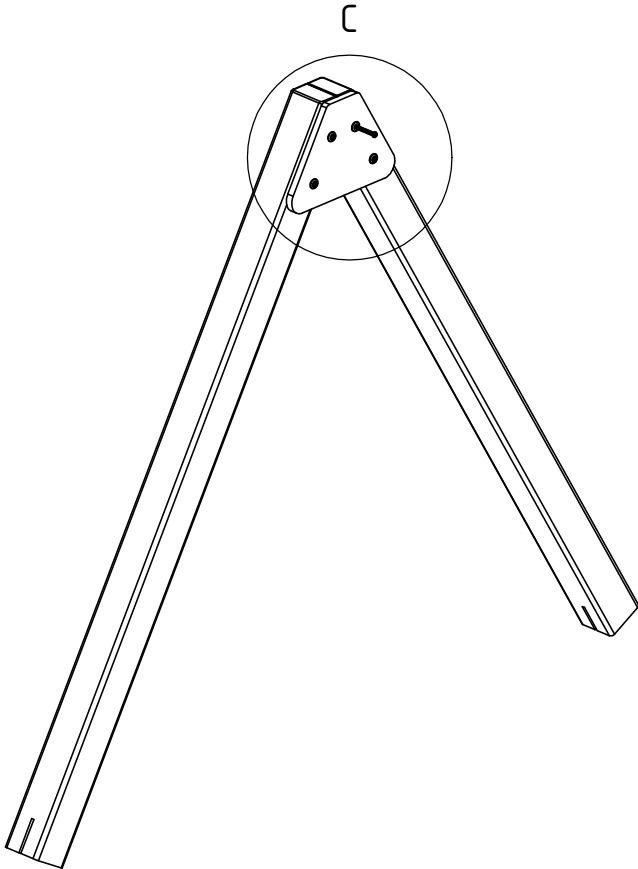

C (1 : 3)

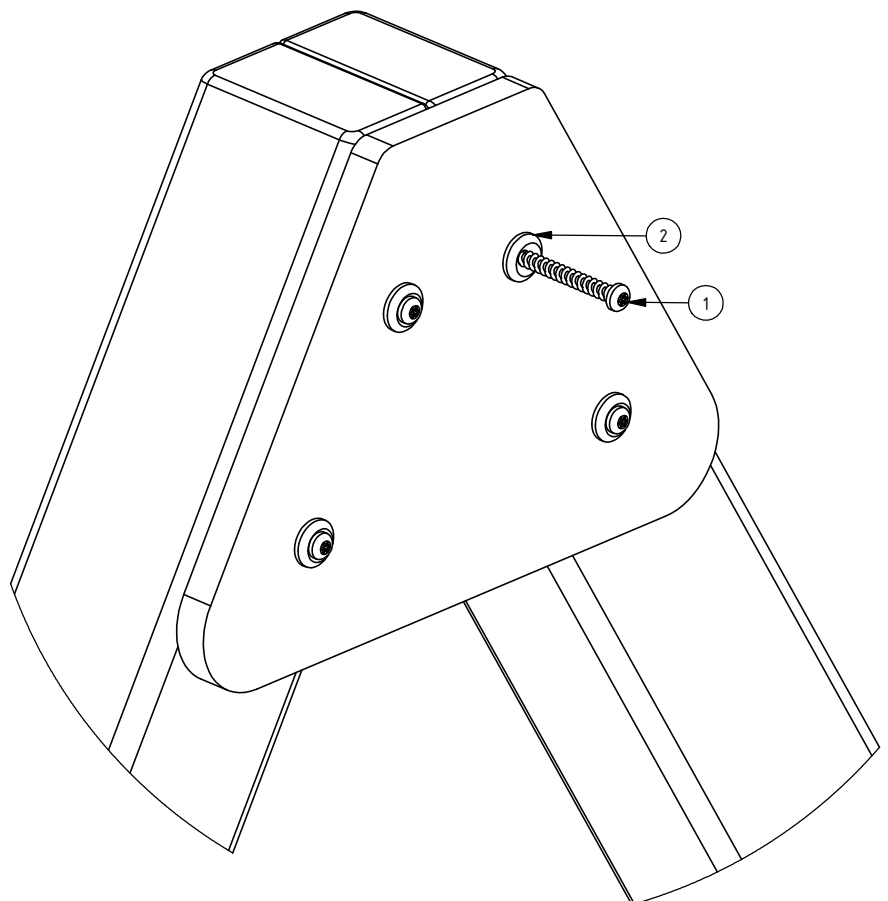



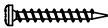
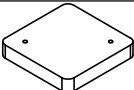

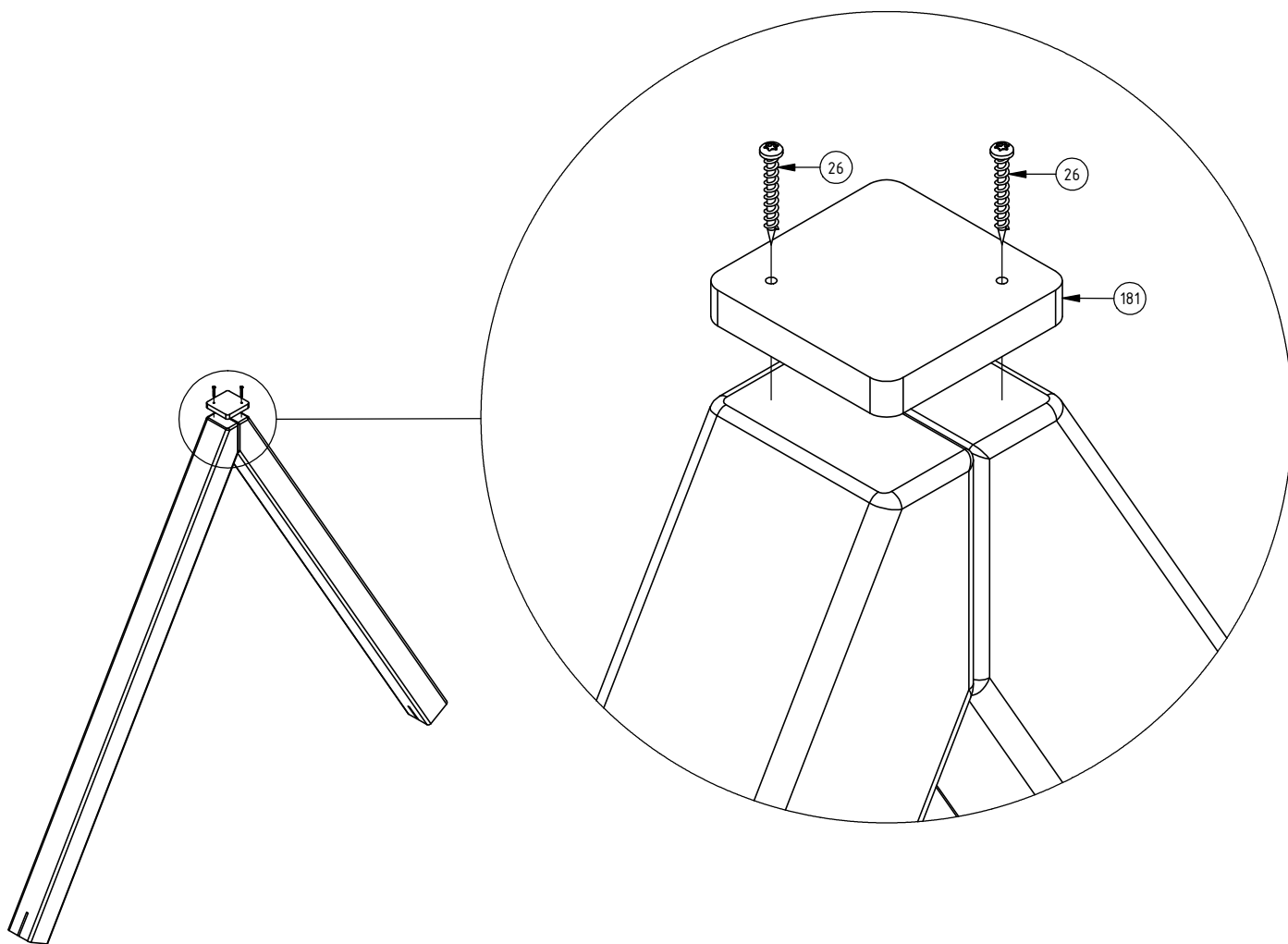
INST_80_44B

Nr	Σ	Element	DIN	ELEMENT
26	2		-	S4x40
181	1		-	F80X_6_PE_g15

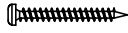

INST_Z_3

Nr	Σ	Element		
1	1		-	S6x60
3	1		-	K2_d30_B
21	1		DIN 125	8x16
213	1		-	Z_NA_1
214	1		-	Z_NA_2

